

# DM8026

## Micro Differential Pressure Meter

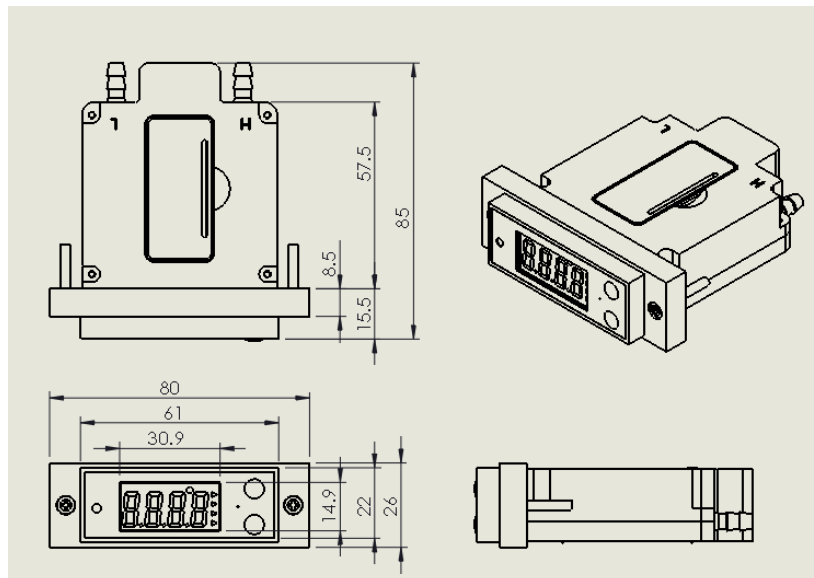

### Specifications:

Pressure range(F.S)	0 ~ ±1.5kPa
Power Voltage	CR123A
Display Update	Selectable for 0.1 to 3 seconds
Battery Life	<b>2 years as Display Update = 1 second &amp; no backlight &amp; no alarm</b>
Accuracy	±1% F.S (@25±3°C) / ±2% F.S (-10 ~ +60°C)
Measure fluid	Air and non-combustible, compatible gases.
Units	in kPa
Current Consumption	1mA maximum (No Backlight)
Working temperature	-10 ~ +60°C
Compensated Temperature Limits	0~50°C (32~122°F)
Size	80mm*85mm*26mm
Water proof	No
Long Term Stability	±1.0% F.S. per year
Thermal Effect	±0.05% F.S/ °F typ. ; ±0.10% F.S/ °F for ranges 1" w.c. and below.
Display	4-digit LCD (Digit : 0.43"H * 0.19"W) with yellow-green backlight
Auto Off Time	1~10 minutes or no auto-off function

### Comparison Table of Pressure and Resolution

F.S.\Unit	kPa	Pa	MPa	bar	Mbar	psi	Kg/cm <sup>2</sup>	mm-Hg	In-Hg	In-H <sub>2</sub> O	mm-H <sub>2</sub> O
1.5kPa	0.001	1	---	0.001	0.01	0.001	0.001	0.01	0.001	0.001	0.1